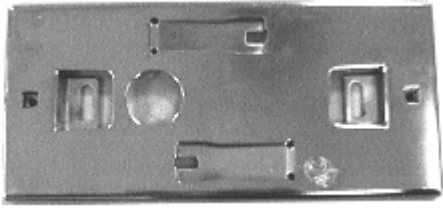
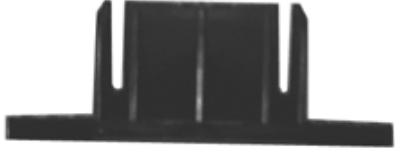

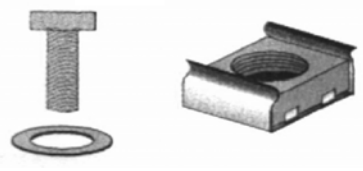
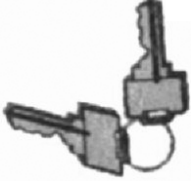

TABLE OF CONTENTS

| | |
|--|----|
| PARTS LIST | 16 |
| SIGNS USED IN SAFETY NOTES..... | 17 |
| CONFORMITY TO REGULATIONS..... | 18 |
| PREPARATORY STEPS..... | 19 |
| CONNECTION LAYOUT | 19 |
| INSTALLATION | 20 |
| MOTOR OVERRIDING SYSTEM..... | 20 |
| MOUNTING THE RACK..... | 21 |
| INSTALLING THE LIMIT SWITCHES | 21 |
| MOTOR SPECIFICATIONS | 22 |
| ATTACHMENTS..... | 22 |
| CONTROL BOARD | 23 |
| PROGRAMMING VERSION PRGS433PPV2 | 23 |
| WIRELESS DATA STORAGE | 23 |
| DELETING ALL THE CODES IN THE MEMORY..... | 23 |
| ATTEMPT TO STORE A CODE ALREADY PRESENT IN THE MEMORY..... | 23 |
| USING THE PROGRAMMER..... | 24 |
| PROGRAMMING VERSION PRGS433RYV2 | 24 |
| WIRELESS STORAGE OF THE REMOTE CONTROL CODE | 24 |
| REPLACING THE CODE | 24 |
| INSTALLATION | 24 |
| ADJUSTING THE POWER AND THE WORKING SCHEDULE | 24 |
| PROGRAMMING THE OPERATION LOGIC | 25 |
| STATUS INDICATORS OF THE BOARD INPUTS | 26 |
| SPECIFICATION | 26 |
| CONNECTIONS TO THE TERMINAL BOARD | 27 |

PARTS LIST

| DESCRIPTION | PHOTO | Q.TY |
|---|--|--|
| <p>ELECTROMECHANIC MOTOR REDUCER FOR SLIDING GATES UP TO 600 KG</p> <p style="text-align: center;">+</p> <p style="text-align: center;">CONTROL UNIT</p> <p style="text-align: center;">+</p> <p style="text-align: center;">CAPACITOR 16 μF</p> |  | <p style="text-align: center;">1</p> <p style="text-align: center;">+</p> <p style="text-align: center;">1</p> <p style="text-align: center;">+</p> <p style="text-align: center;">1</p> |
| <p style="text-align: center;">METAL FASTENING PLATE</p> |  | <p style="text-align: center;">1</p> |
| <p style="text-align: center;">MAGNET HOLDER</p> |  | <p style="text-align: center;">2</p> |
| <p style="text-align: center;">LIMIT SWITCH MAGNETS</p> |  | <p style="text-align: center;">2</p> |
| <p style="text-align: center;">CAGE NUTS</p> <p style="text-align: center;">+</p> <p style="text-align: center;">BOLTS M8 X 30 + WASHERS</p> |  | <p style="text-align: center;">2</p> <p style="text-align: center;">+</p> <p style="text-align: center;">2</p> |
| <p style="text-align: center;">MOTOR OVERRIDING KEY</p> |  | <p style="text-align: center;">2</p> |

CONFORMITY TO REGULATIONS

V2 ELETTRONICA S.p.a. declares that the components included in the kit are in conformity with the provisions of the following EC directives: 93/68/EEC, 73/23/EEC, 99/05/EEC. and that the standards referenced here below:

| ITEM | ELECTRICAL SAFETY | ELECTROMAGNETIC COMPATIBILITY | OFFICIAL USE OF THE SPECTRUM |
|--------------------------------------|-------------------|--|------------------------------|
| M S V 2 | EN 60335 – 1 | EN 61000 – 3 – 2 EN 61000 – 3 – 3 EN 55014 – 1 EN 55014 – 2 | |
| PRGS433PPV2 | EN 60335 – 1 | EN 301 489 – 3 | EN 300 220 – 3 |
| PRGS433RYV2 | EN 60335 – 1 | EN 301 489 – 3 | EN 300 220 – 3 |
| TXC-2, TXC-4, TRC-4, TSC-4, TOV-4 | EN 60950 | ETS 300 683 | EN 300 220 – 3 |
| TRR2/43, T2SAW433, TSR-4 | EN 60950 | ETS 300 683 | EN 300 220 – 3 |
| RIF50 | | EN 50082 – 1 EN 50082 – 2 | |
| EGG220 | EN 60598 – 2 – 1 | EN 50082 – 1 EN 50082 – 2 | |

Racconigi, May 22nd, 2001

V2 ELETTRONICA legal representative.

A.Livio Costamagna



AUTOMATION MUST BE IMPLEMENTED IN COMPLIANCE WITH THE EUROPEAN REGULATIONS IN FORCE:

EN 60204 –1 (MACHINERY SAFETY. ELECTRICAL EQUIPMENT OF MACHINES, PART 1: GENERAL RULES)
 EN 12445 (SAFE USE OF AUTOMATED LOCKING DEVICES, TEST METHODS)
 EN 12453 (SAFE USE OF AUTOMATED LOCKING DEVICES, REQUIREMENTS)

PREPARATORY STEPS

CAREFULLY OBSERVE EUROPEAN REGULATIONS EN12445 AND EN12453 (WHICH REPLACE UNI 8612).

Always check the following:

- Your gate should have a strong and suitable build; no wickets should be present on the sliding gate.
- The sliding gate should not tilt excessively during its entire run.
- The gate should be able to slide freely on its guiding surface without an excessive friction.
- Install both closing and opening limit switches, in order to prevent the gate going off the guiding surface.
- Remove any manual locks.
- Bring power cable ducts near the bottom of the gate (diameter 20 / 30 mm) and of the external devices (photocells, flasher, key selector).

CONNECTION LAYOUT

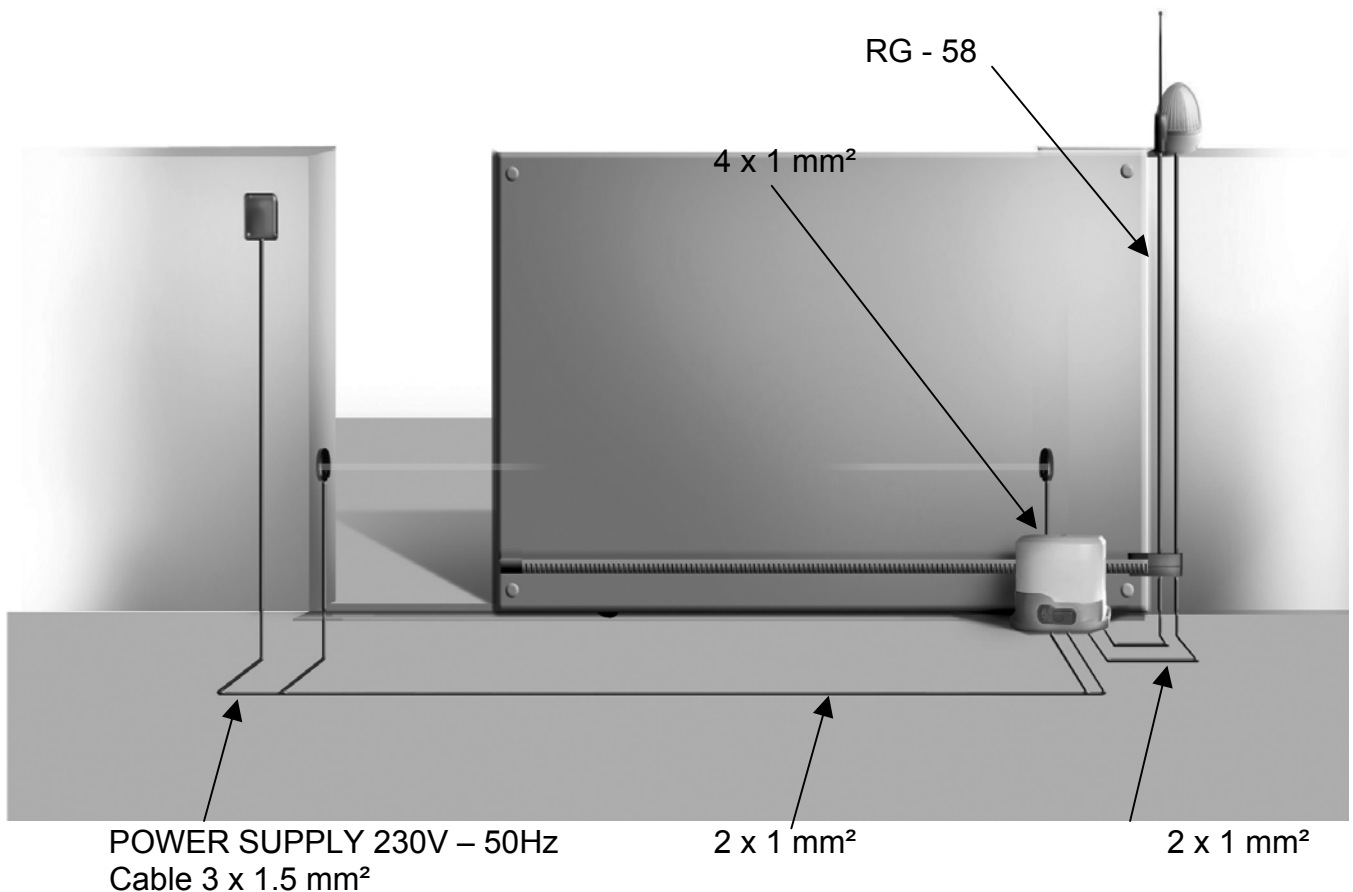

CAUTION!!! : ALL THE CABLES USED FOR THE INSTALLATION MUST BE MARKED WITH **T100°C**.

INSTALLATION

- Prepare a cement base raised 40 - 50 mm from the ground on which the metal plate will be fixed.
- Provide a channel for two hoses that will house the cables in the main hole (D) on the counter-plate. Such counter-plate shall be fixed to the ground by means of two anchors next to the already-made holes (A), or sinking the special fins in the cement (B).
- Fix the motor on the counter-plate by means of the cage nuts fitted in the holes (C).

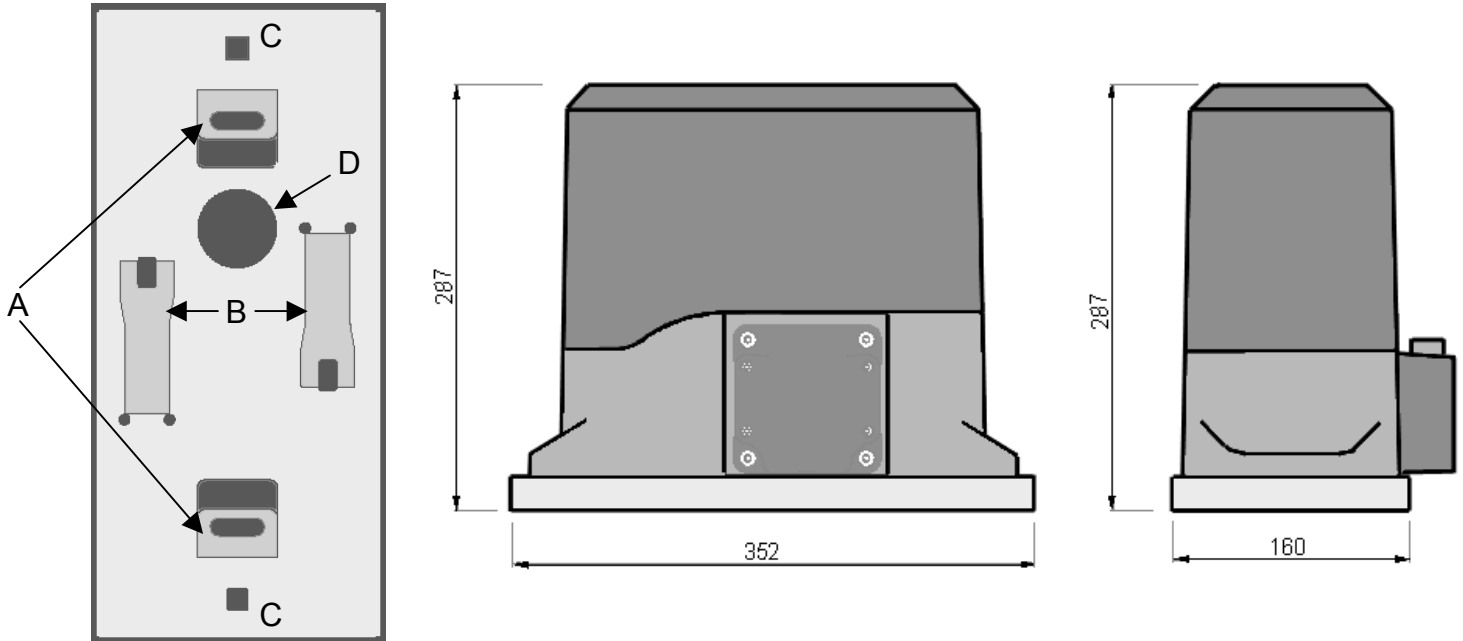

MOTOR OVERRIDING SYSTEM

In case of a blackout, the gate can be operated directly from the motor. Insert the key supplied in the lock **1** on the front side of the motor, perform $\frac{1}{4}$ of a turn and open the plastic door completely.

To restore the automation, simply close the door, rotate the key in closed position and slide the specially provided plastic cover onto the lock.

ATTENTION! In case the leaf overruns its final position and impacts against the safety stroke end (i.e. wrong regulation of the limit switches), and a manual unclamp would be necessary, before using the above procedure, you have to replace the leaf setting away from the safety stroke end using the flat screw on the main motor shaft **2** with a screwdriver.

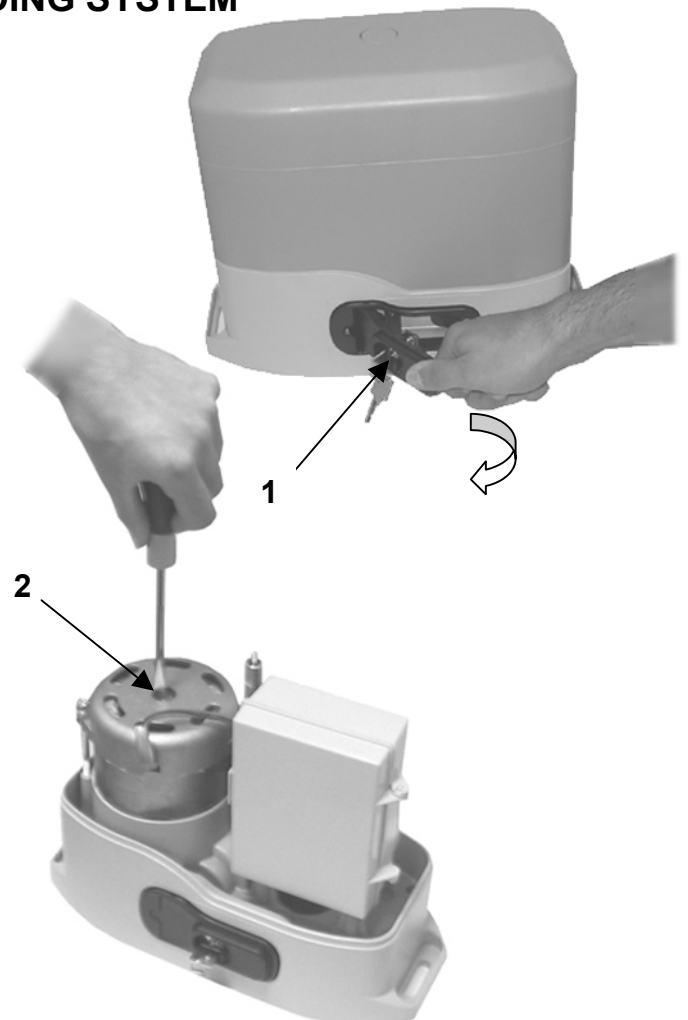

MOUNTING THE RACK

Release the motor and turn the gate completely open.

Fix all the rack elements to the gate, making sure that they stand at the same height than the motor pinion.

It is important that the rack be positioned 1 or 2 mm above the motor pinion, in order to prevent that the motor be damaged under the weight of the gate.

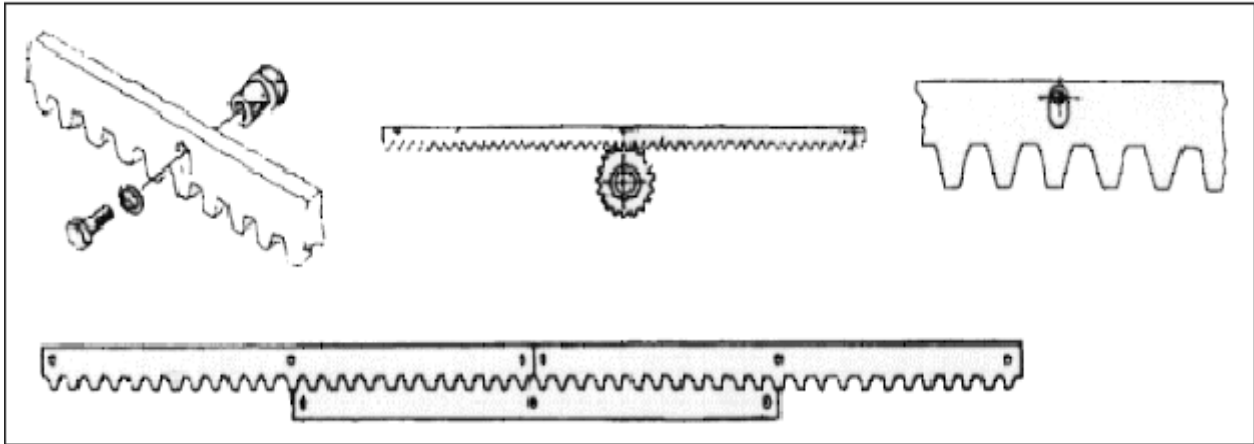

INSTALLING THE LIMIT SWITCHES

Install the supplied magnet holder on the rack in a way that, in the opening and closing limit positions, the magnet be positioned next to the magnetic sensor behind the hood (as near as possible to the hood).

The supplied magnets have been colored differently in order to be distinguished from each other:

RED MAGNET = CLOSING LIMIT SWITCH

BLUE MAGNET = OPENING LIMIT SWITCH

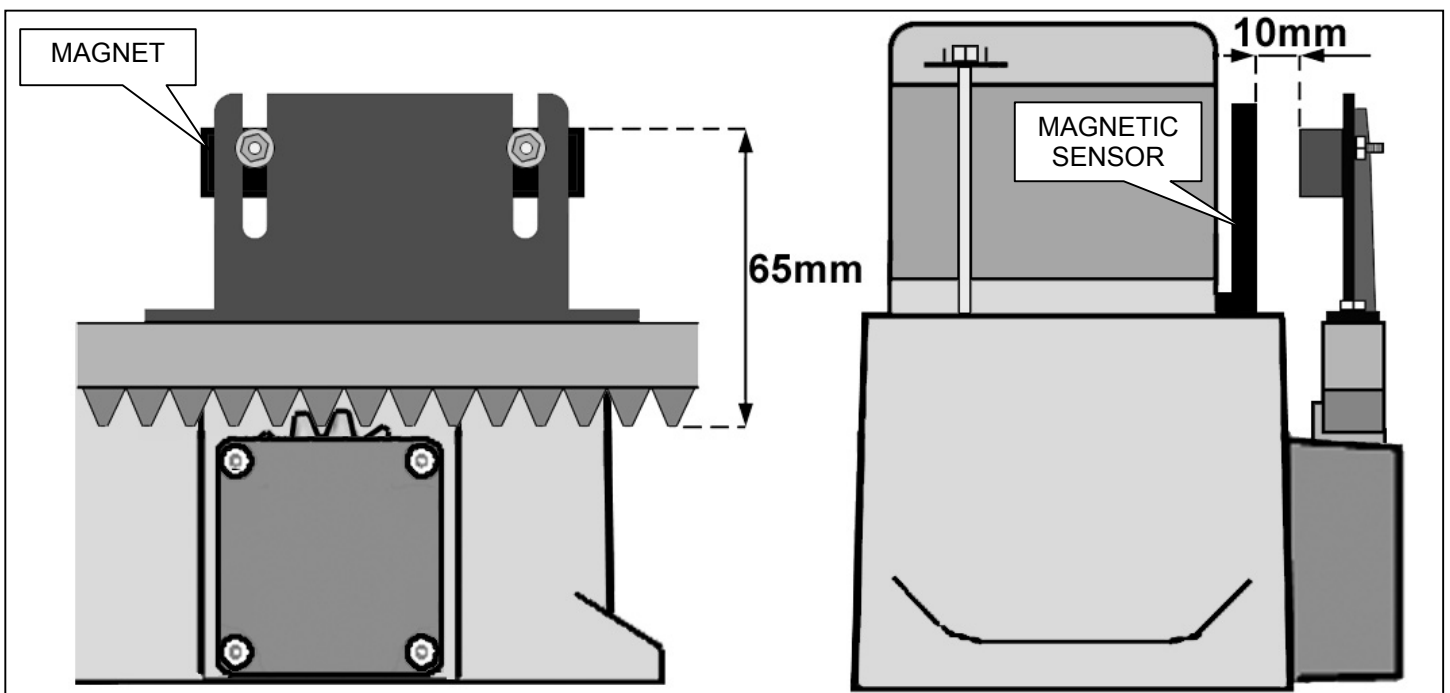

IMPORTANT:

In order to guarantee the best operation of the automation it is essential for the magnets to be positioned at the same height than the magnetic sensor (see above figure). It is also important that the magnet be positioned as near as possible to the sensor, without striking against the motor hood.

MOTOR SPECIFICATIONS

| | |
|-----------------------|---------------|
| GATE MAXIMUM WEIGHT | 600 kg |
| POWER SUPPLY | 230 VAC 50 Hz |
| MAXIMUM POWER | 500 W |
| IDLING CURRENT | 1.6 A |
| FULL LOAD CURRENT | 2 A |
| CAPACITOR | 16 μ F |
| GATE MAXIMUM SPEED | 0.16 m/s |
| MAXIMUM THRUST | 480 N |
| WORK CYCLE | 30% |
| PINION | M4 – Z12 |
| OPERATION TEMPERATURE | -20°C ÷ 60°C |
| MOTOR WEIGHT | 10 kg |
| IP | 44 |

ATTACHMENTS

PHOTOCELL

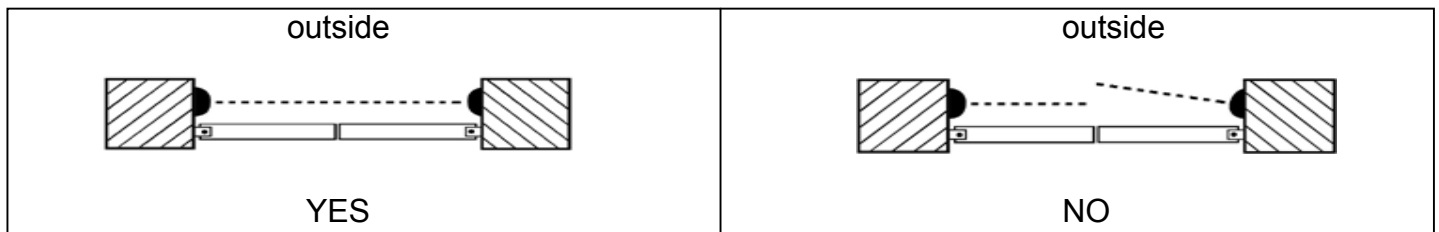

Photocells are placed externally facing one another, at a distance of ca. 40 cm from the ground and 10 cm from the gate.

Operation: if someone walks through the photocells when the gate is closing, the gate stops and opens again to prevent touching the obstacle.

FLASHING LIGHT

The flashing light must be placed in a way that it can be seen from both the outside and the inside; it must be mounted on the column or on its external face.

EXTERNAL ANTENNA

Long-range 433.92-MHz antenna with a mounting support and a 2,5-m RG58 coaxial cable.

OPENING KEY

Activates the gate opening manually. It must be installed on the column, internally or externally.

CAUTION: It cannot be used to open the gate when there is no electricity. If this is the case, release the motors with the specially provided unlock key.



WHEN CONNECTING ATTACHMENTS TO THE CONTROL STATION, REFER TO THE RELEVANT TABLE IN SECTION **BOARD TERMINAL CONNECTIONS**, IN THE NEXT CHAPTER.

CONTROL UNIT

DESCRIPTION

The new programmable unit **PRGS433PPV2** (for Personal Pass radio system kits) or **PRGS433RYV2** (for Royal radio system kits) is used in automated systems for sliding gates, and guarantees a fast and easy installation. Programming the operation logic and the working schedule is extremely easy and prompt; besides, the five control LEDs on the unit allow a continuous monitoring of the input statuses. Thanks to an automatic electronic check, outputs toggle at zero current, with no scintillation effect on the relays.

PROGRAMMING VERSION PRGS433PPV2

Version PRGS433PPV2 allows storing up to 83 different codes, deleting all the codes in the memory and inputting new ones afterwards.

WIRELESS STORAGE OF CODES

To correctly store a code, a minimum distance of 1.5 meters should be observed between the transmitter and the receiver antenna. To wireless-store the required codes, proceed as follows:

- Press and hold button PROG. RX until LED L1 lights up.
- Press and hold transmitter button until LED L1 goes out: the LED goes out for about half a second, thus showing a correct storing of the code; immediately, the LED starts flashing a number of times according to the memory zone just occupied.

When the flashing stops, the system is ready for use.

IMPORTANT: each stored code is associated to the START command only.

TOTAL DELETION OF THE CODES IN THE MEMORY

Strictly follow these steps:

- Disconnect the unit power line.
- Press and hold programming button PROG. RX.

At the same time, reconnect the power line: when programming LED L1 flashes, release button PROG. RX.

Now the 83 zones of memory are empty and available for a new programming process.

A partial deletion of codes is only possible with programming device PROG - 2.

ATTEMPT TO STORE A CODE ALREADY PRESENT IN THE MEMORY

If an attempt is made to store a code already present in the memory, programming LED L1 performs a number of flashes that equals the one concerning the zone of memory already occupied. Differently from the normal code programming function, the LED flashes with a higher frequency and the last flash has duration of about 2 seconds.

The user can take advantage of such a function to identify, at any time, the zone of memory where every single transmitter accessing the system has been stored.

USING THE PROGRAMMER

The storage of remote control codes and the handling of the receiver memory contents can be performed with programming device PROG-2. Refer to PROG-2 Operation Manual for a correct use of the programming device.

PROGRAMMING VERSION PRGS433RYV2

Version PRGS433RYV2 uses ROYAL or 53200 series transmitters manufactured by V2 ELETTRONICA.

WIRELESS STORAGE OF A REMOTE CONTROL CODE

To correctly store the code, a minimum distance of 1.5 meters between the transmitter and the receiver antenna must be observed.

To wireless-store the required code, proceed as follows:

- Code the transmitter dip-switch
- Press and hold button PROG. RX until LED L1 lights up
- Press and hold the transmitter button until LED L1 goes out.

IMPORTANT: the stored code is associated to the START command only.

CHANGING THE CODE

The stored remote code can be changed with a new code, with the same procedure used for storage. This way, the new code will overwrite the old one.

INSTALLATION

The installation engineer must make sure to install a device (e.g. a circuit breaker) that guarantees an omnipolar isolation of device PRGS433RYV2/PRGS433PPV2 from the power line.

The relevant regulations provide that contacts in each terminal be at least 3 mm apart (EN 60335-1).

The device must be fitted in the specially provided housing inside the motor.

ADJUSTING THE POWER AND THE OPERATION SCHEDULE

The power and the operation schedule can be adjusted by means of three potentiometers located on the CONTROL UNIT:

POWER: motor power.

T. WORK: time of working.

T.PAU : time of pausing (only if the CONTROL UNIT is programmed to close automatically).

PROGRAMMING THE OPERATION LOGIC

Several operation modes of the unit are available to be chosen, by changing the dip-switch positions on the unit accordingly. In the following, two tables are displayed explaining the functions associated to every single dip-switch for both models.

| | PRGS433PPV2 | ON | OFF |
|-------|---|--|---|
| DIP 1 | PREFLASH (the flasher activates 2 seconds before the motors start) | Active | Not active |
| DIP 2 | AUTOMATIC CLOSING (the gate will close again after the set pausing time T.PAU) | Active | Not active |
| DIP 3 | START COMMAND DURING THE OPENING | The unit does not senses the START command during the opening | The unit senses the START command during the opening |
| DIP 4 | START COMMAND LOGIC | The START pulse train performs a step-by-step operation: opens – stops – closes – stops... | A START pulse during the opening immediately commands the closing |
| DIP 5 | ROLLING CODE | Active | Not active |
| DIP 6 | PHOTOCELL | Also active during the opening | Not active during the opening |

In this version the motor starting is always active.

| | PRGS433RYV2 | ON | OFF |
|-------|---|--|---|
| DIP 1 | PREFLASH (the flasher activates 2 seconds before the motors start) | Active | Not active |
| DIP 2 | AUTOMATIC CLOSING (the gate will close again after the set pausing time T.PAU) | Active | Not active |
| DIP 3 | START COMMAND DURING THE OPENING | The unit does not senses the START command during the opening | The unit senses the START command during the opening |
| DIP 4 | START COMMAND LOGIC | The START pulse train performs a step-by-step operation: opens – stops – closes – stops... | A START pulse during the opening immediately commands the closing |
| DIP 5 | MOTOR STARTING (2 sec.) | Active | Not active |
| DIP 6 | PHOTOCELL | Also active during the opening | Not active during the opening |

The photocell can never be disabled during the closing.

IMPORTANT: with the automatic closing function (dip switch 2 in ON position) it is advisable to select dip-switch 4 OFF. This will prevent a failure in the automation when a START command is given during the automatic closing.

Only use a flash without internal intermittence.

STATUS INDICATORS OF THE UNIT INPUTS

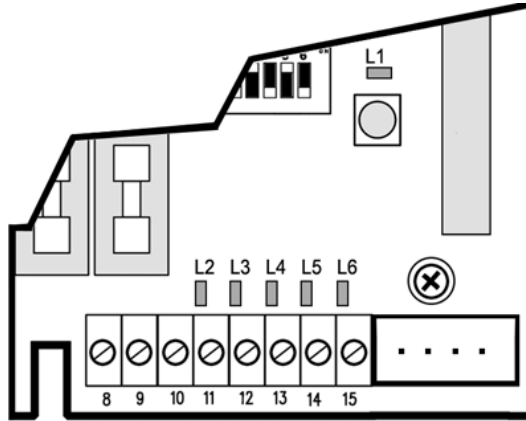

| INDICATOR | FUNCTION |
|-----------|---|
| L1 | Programming |
| L2 | START: lights up when a pulse is received at the START input terminal |
| L3 | STOP: goes out when a pulse is received at the STOP input terminal |
| L4 | PHOTOCCELL: goes out when a pulse is received at the PHOTO input terminal |
| L5 | OPENING LIMIT SWITCH: goes out when a pulse is received at the opening limit switch input terminal |
| L6 | CLOSING LIMIT SWITCH: goes out when a pulse is received at the closing limit switch input terminal. |

SPECIFICATIONS

| | |
|------------------------------------|--|
| Power supply | 230 VAC 50 Hz |
| Maximum load on a motor | 700 W |
| Maximum load on 24 VAC attachments | 3 W |
| Working room temperature | -20 ÷ +60 °C |
| Fuses | 5 A delayed for 220 VAC line 160 mA delayed for 24 VAC line 250 mA delayed for 12 VAC line |
| Dimensions | 150 x 130 x 100 mm |
| Weight | 650 g |

CONNECTIONS TO THE TERMINAL BOARD

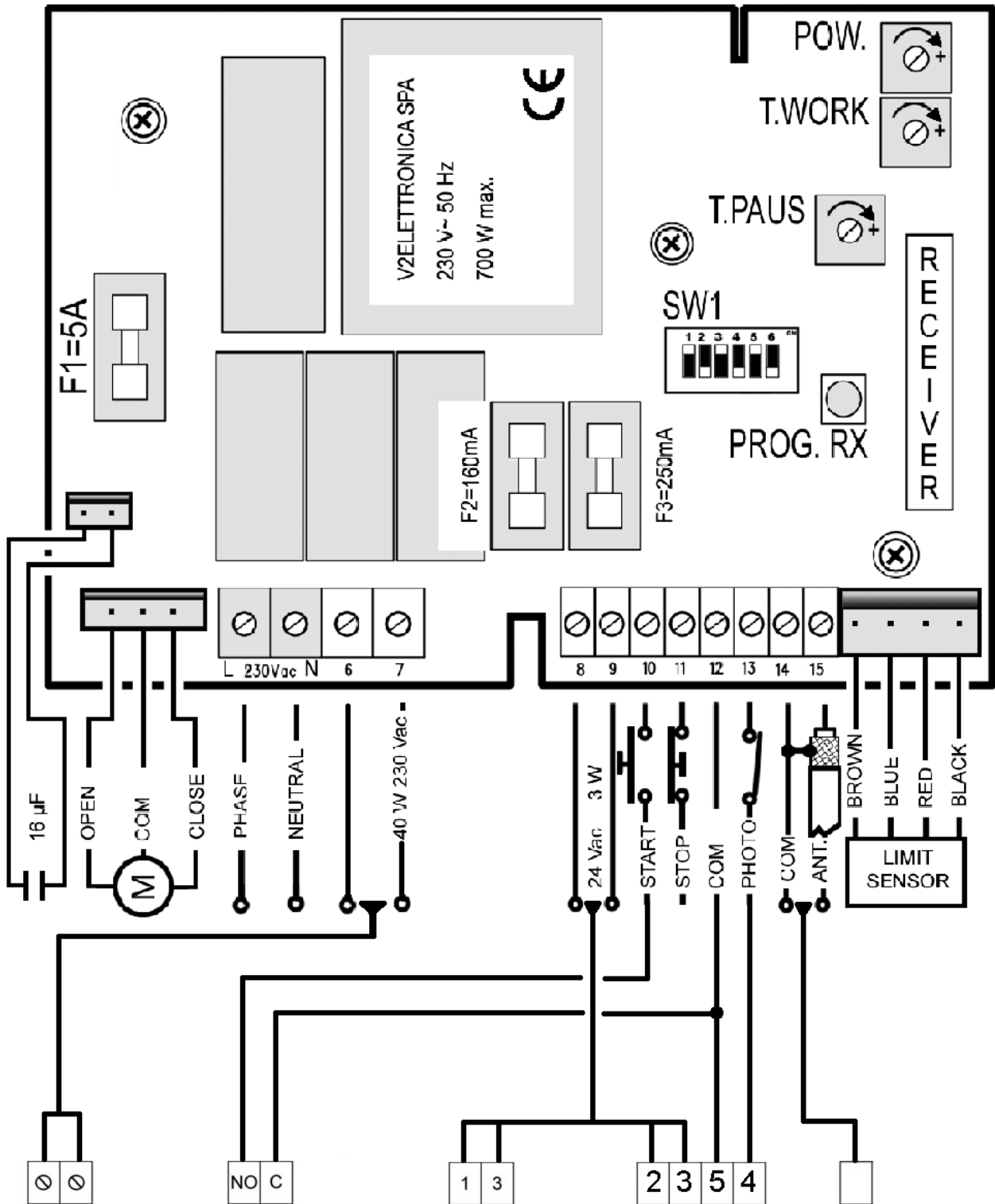

IMPORTANT:

Normally closed inputs (STOP, PHOTO), if not used, must be bridged through the common terminal (-)

| TERMINAL | CONNECTION |
|-----------------|---|
| 1. | Motor power supply during the opening 230 VAC |
| 2. | Motor common terminal |
| 3. | Motor power supply during the closing 230 VAC |
| 4. | Power supply phase wire 230 VAC |
| 5. | Power supply neutral wire 230 VAC |
| 6-7. | Flasher 230 V c.a. / 40 W |
| 8-9. | Power supply output 24 VAC / 6 W for photocells and other attachments |
| 10. | Opening command for connections to: button panel, key selector, and clock. Normally open contact (indicator L2) |
| 11. | STOP command. Normally closed contact (indicator L3) |
| 12. | Common (-) |
| 13. | Photocell. Normally closed contact (indicator L4) |
| 14. | Antenna cable shielding |
| 15. | Antenna |
| 16-17-18-19. | Limit switch magnet sensor (FCA indicator L5 / FCC indicator L6) |

The connection between the control board and the motor must be made according to the motor position in respect to the gate. The control board associates an opening to the first START command; therefore, the connector must be positioned in a way (even rotating it by 180° if needed) that the first START command will cause the opening of the gate.