

# INDEX

PROGRAMMING .....	28
CONTROL PANEL .....	28
PROGRAMMING .....	29
FUNCTION OF THE BUTTONS, MENU, UP and DOWN .....	29
STANDARD PROGRAMMING (DEFAULT) .....	29
PERSONALIZED PROGRAMME .....	30
GATE 1 OPENING TIME .....	30
GATE 2 OPENING TIME .....	30
OPENING TIME OF PEDESTRIAN GATE .....	30
CLOSING TIME GATE 1 .....	31
CLOSING TIME GATE 2 .....	31
CLOSING OF PEDESTRIAN GATE .....	31
GATE DELAY DURING OPENING .....	32
GATE DELAY DURING CLOSING .....	32
LOCK TIME .....	32
LOCK ADVANCE TIME .....	32
BACKLASH TIME .....	33
PRE-FLASHING TIME .....	33
MOTOR 1 POWER .....	33
MOTOR 2 POWER .....	34
START OFF .....	34
SLOW DOWN FUNCTION .....	34
START IN OPENING .....	35

# INDEX

START IN CLOSING .....	35
START IN PAUSE .....	35
PEDESTRIAN START IN OPENING .....	36
THE PHOTOCELL IN PAUSE .....	36
AUTOMATIC CLOSING .....	37
COURTESY LIGHTS .....	37
FLASHLIGHT IN PAUSE .....	38
FLASHLIGHT WITH INTERMITTENCE .....	39
CLOCK FUNCTION .....	39
INPUT STOP .....	39
INPUT PHOTO 1 .....	40
INPUT PHOTO 2 .....	40
RADIO INPUTS .....	41
INSERTING THE WISHED CODES INTO THE MEMORY .....	41
SUBSTITUTION OF A SINGLE CODE .....	42
END OF PROGRAMMING .....	42
INSTRUCTIONS FOR THE INSTALLATION .....	42
WARNING LIGHT DESCRIPTION .....	42
TERMINAL CONNECTIONS .....	42
TECHNICAL SPECIFICATIONS .....	43
FUNCTION CHART .....	44
FUNCTION TABLE PD4 .....	47
PCB AND CONNECTIONS .....	49

# PROGRAMMING

The new PD4 electronic programmer, designed and carried out by V2 ELETTRONICA, finds its application in the installations of automated sliding gates with the utmost reliability and safety.

Thanks to the versatility of this product, it is possible to satisfy all requirements with functionality and efficiency.

PD4 is equipped with a display which enables, besides an easy programming, the constant monitoring of the inputs' state; furthermore, its menu structure enables a simple layout of the working times and function logics. It is built by a sophisticated surface assembly technique and it is characterized by the complete electrical isolation between the digital circuit and the power. According to the safety standard UNI 8612, it is equipped with an electronic torque regulator. The presence on board of a quick input connector enables the input of a module receiver of the series MT or MQ: it is therefore possible to employ the four available radio channels, associated to the controls: START, PEDESTRIAN START, STOP and ACTIVATION AUXILIARY EXIT.

Furthermore, this control unit is equipped with an output for the connection of the pilot lamp indicating the state of the gate, and an output to control the switching on and off of the courtesy lights.

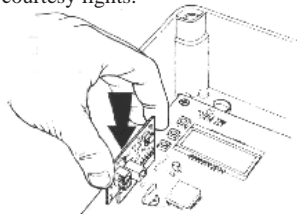

PLUG-IN RECEIVER INSERTION

## CONTROL PANEL

First of all make the connections mentioned above before switching on the power station.

The power station will check DISPLAY 's correct functioning activating the different sections for 1,5 seconds



After this, on the display appears the software version for 1,5 seconds. Example:

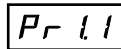

The display shows the control panel:

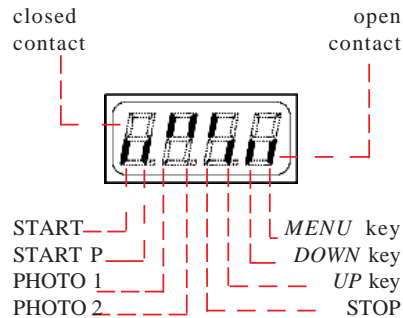

The control panel shows the actual state of the contacts and programming keys: if the contact is closed the higher section is illuminated, if the contact is open, the lower section is illuminated. The above drawing shows an example in which the connections have been correctly carried out: START, START P PHOTO1, PHOTO2 and STOP.

# PROGRAMMING

## PROGRAMMING

The programmer PD4 presents a menu programming structure, each of them corresponding to a function of the programmer (function menu) or to the setting of the working time (time menu). The time menu enables the setting of the programmer working times (Ex.: door opening or closing time, locking time, preflashing time, etc.) and they can be set from 0 to 120 seconds with a scanning of  $\pm 0,5$  sec. On the other hand, the function menu enables the setting of the wished functions (ex. time courtesy lights, PHOTO1 active as safety rib, PHOTO2 deactivated, etc.). There are time menu depending on specific function menu (Ex.: if the AUTOMATIC CLOSING is activated, it is necessary to set a PAUSE TIME, if not activated, it is not necessary to set it); therefore to facilitate the programming, these time menu have been enclosed inside the function menu, on which they depend. In particular the menus: AUTOMATIC CLOSING (Ch.AU), LIGHTS (LUCi) and PHOTOCCELL IN PAUSE (Ft.PA) present among the various options a few time menus.

## FUNCTION OF THE BUTTONS, MENU, UP and DOWN

When the programming function is activated, press the button UP or DOWN to select the menu, by shifting forward or backward (keep the button pressed for a quick shifting). Press the button MENU to enter the settings which can be modified by pressing the buttons UP and DOWN.

WHEN THE PROGRAMMING

FUNCTION IS NOT ACTIVE, PRESSING THE BUTTON UP CORRESPONDS TO THE CONTROL START, PRESSING THE BUTTON DOWN CORRESPONDS TO THE CONTROL PEDESTRIAN START: IT IS POSSIBLE TO CHECK THE SYSTEM NOW.

After supplying power, the display must show the control panel (make sure that the connections are correct).

Keep the MENU button pressed until the display shows:



Now the programming is activated: if within 1 minute no operation is carried out, the programming goes automatically off displaying again the control panel. We can define the programming of the PD4 by two different ways: STANDARD PROGRAMMING (DEFAULT) and PERSONALIZED PROGRAMMING.

## STANDARD PROGRAMMING (DEFAULT)

dEF is the Default program set by V2 Elettronica. If you wish to memorize it, proceed as follows.

Press MENU key: the display show no.

Press MENU key to confirm: the display shows dEF.



Press DOWN key: the display shows FinE.

# PROGRAMMING

Press *MENU* key: the display shows **no.**

**no**

Select the option **Si** pressing *UP* or *DOWN*.

**5,**

Press *MENU* key to confirm: the display shows the control panel.

The default standard data have been memorized and the control unit is ready to be used.

## PERSONALIZED PROGRAMME

This type of programme enables you to change the working times and all the main functions, according to the user's requirements: by pressing *UP* or *DOWN* keys is possible to select the wished menu (For a quick shifting keep the key pressed. After the amendment, press the key "END OF PROGRAMMING" and quit: the new data has been memorized.

ATTENTION: in case no inputs are made for more than 1 minute, the control box goes automatically out from the programme and the amendment are not memorized.

## GATE 1 OPENING TIME

This menu is adjustable from 0 to 120 seconds ( $\pm 0,5$ ) and determines the time for the opening of gate 1.

Press *UP* or *DOWN* keys, until the display shows:

**tAP1**

Press the *MENU* key, the display shows:

**225**

Set the wished time pressing the *UP* or *DOWN* keys.

Press the *MENU* key to confirm: the display shows the writing: **t.AP1.**

## GATE 2 OPENING TIME

This menu is adjustable from 0 to 120 seconds ( $\pm 0,5$ ) and determines the time of opening of gate 2.

Press *UP* or *DOWN* keys, until the display shows:

**tAP2**

Press the *MENU* key, the display shows:

**225**

Set the wished time pressing the *UP* or *DOWN* keys.

Press the *MENU* key to confirm: the display shows the writing: **t.AP2.**

## OPENING TIME OF PEDESTRIAN GATE

This menu is adjustable from 0 seconds to t.AP1 ( $\pm 0,5$ ) and determines the opening time of gate 1.

Press *UP* or *DOWN* keys, until the display

# PROGRAMMING

shows:

**tAPP**

Press the *MENU* key, the display shows:

**60**

Set the wished time pressing the *UP* or *DOWN* keys.

Press the *MENU* key to confirm: the display shows the writing: **t.APP.**

## CLOSING TIME GATE 1

This menu is adjustable from 0 to 120 seconds ( $\pm 0,5$ ) which is the closing time for gate 1. To avoid the uncompleted closing of the gate, we suggest to set a longer opening time of t.AP1.

Press *UP* or *DOWN* keys, until the display shows:

**tCh1**

Press the *MENU* key, the display shows:

**235**

Set the wished time pressing the *UP* or *DOWN* keys.

Press the *MENU* key to confirm: the display shows the writing **t.Ch1.**

## CLOSING TIME GATE 2

This menu is adjustable from 0 to 120 seconds ( $\pm 0,5$ ) which is the closing time for gate 2. To

be sure of the perfect closing of the gate, we suggest to set a longer opening time t.AP2.

Press *UP* or *DOWN* keys, until the display shows:

**tCh2**

Press the *MENU* key, the display shows:

**235**

Set the wished time pressing the *UP* or *DOWN* keys.

Press the *MENU* key to confirm on the display will appear: **t.Ch2.**

## CLOSING OF PEDESTRIAN GATE

This menu is adjustable from 0 to t.Ch1 ( $\pm 0,5$ ) and determines the closing time of gate 1. In order to avoid the uncompleted closing of the gate, we suggest to set a longer opening time of t.APP.

Press *UP* or *DOWN* keys, until the display shows:

**tChP**

Press the *MENU* key, the display shows:

**70**

Set the wished time pressing the *UP* or *DOWN* keys.

Press the *MENU* key to confirm: on the display will appear: **t.ChP.**

# PROGRAMMING

## GATE DELAY DURING OPENING

In order to avoid any collision of the gate during the opening phase, the time of delay should be introduced **r.AP**, which is adjustable from 0 to 120 seconds ( $\pm 0,5$ ). In such a case the opening time of gate 2 is delayed in comparison to the gate 1.

Press the keys *UP* or *DOWN* until the display shows:

**r.AP**

Press the *MENU* key, on the display will appear:

**10**

Set the wished time pressing the *UP* or *DOWN* keys.

Press the *MENU* key to confirm, on the display will appear **r.AP**.

## GATE DELAY DURING CLOSING

In order to avoid the colliding of gate's during the closing the time of delay should be introduced **r.Ch**, which is adjustable from 0 to 120 seconds ( $\pm 0,5$ ). In such a case the closing time of gate1 is delayed in comparison to the gate2.

Press the keys *UP* or *DOWN* until the display shows:

**r.Ch**

Press the *MENU* key, the display shows:

**30**

Set the wished time pressing the *UP* or *DOWN* keys.

Press the *MENU* key to confirm, on the display will appear **r.Ch**.

## LOCK TIME

When the gate starts the opening phase, the control unit must excite the electrolock in order to hook it out and enable the opening of the gate. The time **t.SEr** determines the duration of excitation, and is adjustable from 0 to 120 seconds ( $\pm 0,5$ ).

Press the keys *UP* or *DOWN* until the display shows:

**t.SEr**

Press the *MENU* key, the display shows:

**30**

Set the wished time pressing the *UP* or *DOWN* keys.

Press the *MENU* key to confirm, on the display will appear **t.SEr**.

## LOCK ADVANCE TIME

This menu permits to anticipate the excitation of the lock on a set time from 0 to t.SEr (with a scanning of  $\pm 0,5$ ). During the advance locking time the gate does not move so to

# PROGRAMMING

always guarantee the unhooking of the electrical lock.

Press the keys *UP* or *DOWN* until the display shows:

**t.ASE**

Press the *MENU* key, the display shows:

**00**

Set the wished time pressing the *UP* or *DOWN* keys.

Press the *MENU* key to confirm, on the display will appear **t.ASE**.

## BACKLASH TIME

To avoid that the gate starts the opening phase before the electrical locks is unhooked, it is possible to introduce a time of inversion adjustable from 0 to 120 seconds ( $\pm 0,5$ ). In this way during the opening phase, the gate inverts the motion through the set time permitting the unhooking of the electrical lock.

Press the keys *UP* or *DOWN* until the display shows:

**t.inu**

Press the *MENU* key, the display shows:

**00**

Set the wished time by pressing the *UP* or *DOWN* keys.

Press the *MENU* key to confirm, on the display will appear **t.inv**.

## PRE-FLASHING TIME

This menu permits the introduction of a pre-flashing that occurs before any movement of the gate either in opening or in closing phase: the time of pre-flashing can be adjusted from 0 to 120 seconds ( $\pm 0,5$ ).

Press the keys *UP* or *DOWN* until the display shows:

**t.PrE**

Press the *MENU* key, the display shows:

**10**

Set the wished time pressing the *UP* or *DOWN* keys.

Press the *MENU* key to confirm, on the display will appear **t.PrE**.

## MOTOR 1 POWER

This menu permits to adjust the motor 1 power from 1 to 10 with a scanning of  $\pm 1$ .

Press the keys *UP* or *DOWN* until the display shows:

**Pot 1**

Press the *MENU* key, the display shows:

# PROGRAMMING

4

Set the wished value pressing the *UP* or *DOWN* keys.

Press the *MENU* key to confirm, on the display will appear **Pot1**.

## MOTOR 2 POWER

This menu permits to adjust the motor 2 power from 1 to 10 with a scanning of  $\pm 1$ .

Press the keys *UP* or *DOWN* until the display shows:

Pot2

Press the *MENU* key, the display shows:

4

Set the wished value pressing the *UP* or *DOWN* keys.

Press the *MENU* key to confirm, on the display will appear **Pot2**.

## START OFF

When the gate is at a standstill and is going to move, it is contrasted by the starting inertia. As a consequence of this, if the gate is very heavy the gates might not move. By activating the start off function, it is possible to win the initial inertia thanks to the motor start to the maximum of the power for 2 seconds.

Press the keys *UP* or *DOWN* until the display shows:

SPUn

Press the *MENU* key, the display shows one of the 2 writings:

**no** the motor start to the maximum the power is not activated.  
**Si** the motor start to the maximum the power is activated.

Set the wished functions pressing the *UP* or *DOWN* keys.

Press the *MENU* key to confirm, on the display will appear **SPUn**.

## SLOW DOWN FUNCTION

This menu can enable the slow down function for the gate. If the function is on, two different speeds can be selected.

Press the keys *UP* or *DOWN* until the display shows:

rALL

Press the *MENU* key, the display shows one of the 2 writings:

**vEL1** Function on with slow down at speed 1 (slow)  
**vEL2** Function on with slow down at speed 2 (fast)  
**no** Function off.

# PROGRAMMING

Set the wished functions pressing the *UP* or *DOWN* keys.

Press the *MENU* key to confirm, on the display will appear **rALL**.

**ATTENTION:** if the slow down function is on, the opening and the closing time must be smaller than the time necessary for the complete running. Consequently the gate starts the slow down phase before to reach the stop point. This guarantees the correct functioning of the system.

## START IN OPENING

This menu permits to select the functions of start during the opening phase.

Press the keys *UP* or *DOWN* until the display shows:

SEAP

Press the *MENU* key, the display shows one of the 3 writings:

**no** the command START is not available.  
**ChiU** the command START close the gate.  
**PAUS** the command START stop the gate and goes into in PAUSE.

Set the wished functions pressing the *UP* or *DOWN* keys.

Press the *MENU* key to confirm, on the display will appear **St.AP**

## START IN CLOSING

This menu permits to select the functions of start during the closing phase.

Press the keys *UP* or *DOWN* until the display shows:

SECh

Press the *MENU* key, the display shows one of the 2 writings:

**StoP** the command START stop the gate.  
**APER** the command START open the gate

Press the *MENU* key, the display shows one of the 2 writings.

Press the *MENU* key to confirm, on the display will appear **St.Ch**.

## START IN PAUSE

This menu permits to select the functions of the command start during the standstill.

Press the keys *UP* or *DOWN* until the display shows:

SEPA

Press the *MENU* key, the display shows one of the 2 writings:

**no** the command START is not available. **THIS FUNCTION CANNOT BE SELECTED UNTIL THE AUTOMATIC CLOSING HAS BEEN ACTIVATED (menu Ch.AU).**

# PROGRAMMING

**ChiU** the command START closes the gate. functioning of two photocells during the pause phase.

Set the wished functions pressing the *UP* or *DOWN* keys. Press the keys *UP* or *DOWN* until the display shows:

**FLPA**

Press the *MENU* key to confirm, on the display will appear **St.PA**.

## PEDESTRIAN START IN OPENING

This menu permits to select the functions of the command of START P. during the opening phase.

Press the keys *UP* or *DOWN* until the display shows:

**SPAP**

Press the *MENU* key, the display shows one of the 3 writings:

**PAUS** the command PEDESTRIAN START stops the gate and goes in PAUSE.

**no** the command PEDESTRIAN START is not available

**ChiU** the command PEDESTRIAN START closes the gate.

Set the wished functions pressing the *UP* or *DOWN* keys.

Press the *MENU* key to confirm, on the display will appear **SP.AP**.

## THE PHOTOCCELL IN PAUSE

This menu permits to determine the

Press the keys *UP* or *DOWN* until the display shows:

Press the *MENU* key, the display shows one of the 2 writings:

**rPAU** the interruption of the photocell's ray causes the top of the pause time; when the photocells work again, the pause time restart from zero;

**t.PCh** the interruption of the photocell's ray causes the top of the pause time; when the photocells work again, the gate stops for a time to be set between 0 to 120 seconds.

Set the wished functions pressing the *UP* or *DOWN* keys.

Press the *MENU* key to confirm.

If the function is **t.PCh**, the display shows:

**50**

Press the button *UP* or *DOWN* to program the wished time.

Press the *MENU* key to confirm, on the display will appear: **Ft.PA**.

If the function is **rPAU**, on the display will appear: **Ft.PA**.

# PROGRAMMING

## AUTOMATIC CLOSING

Permits the selection between the semiautomatic or automatic functioning. By the semiautomatic functioning the command of START or PEDESTRIAN START opens the gate, when the opening is complete the gate remains still until the successive command of opening, which will reclose it. On the other hand, it stops automatically and remains in pause phase for the set time (t.PAU), then it closes again through the set closing time. If the cycle is started with a START, the control unit ignores the command START P. until the end of the cycle. The in pause time is adjusted from 0 to 999 seconds.

Press the *MENU* key to confirm, on the display will appear:

**ChAU**

Press the *MENU* key, the display shows one of the 2 writings:

**no** the automatic reclosing is not available, the gate is semiautomatic.

**t.PAU** the reclosing is available, the standstill time is set from 0 to 999.

Set the wished functions pressing the *UP* or *DOWN* keys.

Press the *MENU* key to confirm

If the function is **t.PAU**, the display shows:

**100**

Set the wished time pressing the *UP* or

*DOWN* keys.

Press the *MENU* key to confirm, on the display will appear **Ch.AU**.

If the function is **no**, on the display will appear: **Ch.AU**.

**IMPORTANT:** If the automatic reclosing is not available, it is necessary to have the command START in PAUSE menu **St.PA**).

## COURTESY LIGHTS

Thanks to the connection "courtesy light" the PD4 control unit enables the connection of the courtesy lights (I.E. garden lights), which can work automatically (lights on for the whole cycle) or timed (lights on for a time adjustable from 0 to 999 seconds). The lights turn on with a START or PEDESTRIAN START control. It is also possible to control this connection using the code memorized in the radio input **tEL4**, in this last case the connection "courtesy light" becomes an auxiliary connection to which it is possible to match one of the following functional logics:

**monostable:** it activates the output relay through all the tx transmission time, when the transmission ends the relay is disconnected.

**bistable:** it activates the relay with the tx first transmission, the relay disconnects with the second transmission.

**timer:** the tx transmission triggers the relay which disconnects automatically after a time adjustable between 0 and 999 seconds.

Press the keys *UP* or *DOWN* until the display

# PROGRAMMING

shows:

**LUCi**

Press the *MENU* key, the display shows one of the 3 writings:

- t.LUC** the courtesy lights start from a time adjustable from 0 to 999 seconds.
- CiCL** the courtesy lights are on through the whole cycle.
- AUS** auxiliary exit with adjustable logical functioning.

Set the wished functions pressing the *UP* or *DOWN* keys.

Press the *MENU* key to confirm

If the function selected is **AUX**, one of the following will appear on the display:

- tiM** timed auxiliary exit (time adjustable from 0 to 999 seconds)
- biSt** auxiliary output relay with bistable functioning
- Mon** auxiliary output relay with monostable functioning

Press the *UP* or *DOWN* keys to select the wished function.

Press the *MENU* key to confirm.

If the selected function is **tiM**, on the display will appear:

**600**

Press the *UP* or *DOWN* keys to select the wished time.

Press the *MENU* key to confirm, on the display will appear: **LUCi**.

If the selected function is **biST** or **Mon** on the display will appear **LUCi**.

If the function is **t.LUC**, on the display will appear:

**600**

Press the *UP* or *DOWN* keys to select the wished time.

Press the *MENU* key to confirm, on the display will appear: **LUCi**.

If the function is **CiCL**, on the display will appear: **LUCi**.

## FLASHLIGHT IN PAUSE

This menu permits to activate or to disactivate the flashlight during the pause time.

Press the keys *UP* or *DOWN* until the display shows:

**LP.PA**

Press the *MENU* key, the display shows one of the 2 writings:

- no** not activated flashlight in pause
- Si** activated flashlight in pause

Press the *MENU* key, the display shows one of the 2 writings.

# PROGRAMMING

Press the *MENU* key to confirm, on the display will appear: **LP.PA**.

## FLASHLIGHT WITH INTERMITTENCE

The control unit PD4 permits the connection of a flashlight with or without intermittence. If the flashlight is equipped with an inner intermittence effect, it is necessary to select the option "Si", but if it has no inner intermittence, it is necessary to select the option "no" in order to make it flash.

Press the keys *UP* or *DOWN* until the display shows:

**inLP**

Press the *MENU* key, the display shows one of the 2 writings.

- no** if the flashlight has no inner intermittence
- Si** the clock function is activated

Set the wished functions pressing the *UP* or *DOWN* keys.

Press the *MENU* key to confirm, on the display will appear: **in.LP**.

## CLOCK FUNCTION

This function permits to program the time bands of opening and closing. It is necessary to connect a 24h timer with a contact normally open in parallel with the START

or PEDONAL START input. When the timer contact is closed, the gate gets into opening phase and remains opened until the contact of the timer opens causing the re-closing of the gate.

**IMPORTANT:** FOR A CORRECT FUNCTIONING IT IS NECESSARY TO ACTIVATE THE AUTOMATIC CLOSING (menu **Ch.AU**.)

Press the keys *UP* or *DOWN* until the display shows:

**oroL**

Press the *MENU* key, the display shows one of the 2 writings:

- no** the clock function is not activated
- Si** the clock function is activated

Set the wished functions pressing the *UP* or *DOWN* keys.

Press the *MENU* key to confirm, on the display will appear **oroL**.

## INPUT STOP

This menu permits to select the functions associated to the command of STOP. Press the *UP* or *DOWN* keys until on the display appears:

**StoP**

Press the *MENU* key, the display shows one of the 3 writings:

# PROGRAMMING

**no** the input STOP is not available  
**ProS** the input STOP stops the gate: pressing the command START the gate continues the motion  
**invE** the command STOP stops the gate: at the next START the gate starts moving in the opposite direction.

**NOTE:** During the pause STOP stops the gate: pressing the command START will always re-closing the gate.

Press *UP* or *DOWN* to select the wished function.

Press menu to confirm. the display shows **StoP**.

## INPUT PHOTO 1

This input can be abilitated for the connection of two different safety devices: the photocell or the rib. The rib (contact normally closed) is an active safety device in opening and closing (now active during the backlash): its intervention during the opening phase stops the gate, inverts the motion for 4 s, without offsetting the doors. On the other hand, the intervention of the rib in closing phase stops the gate, inverts the motion with the offset of the doors. The photocell 1 (contact normally closed) is an active security in opening and closing: the intervention of the photocell during the closing stops the gate, at its disengagement the gate inverts the motion: Differently the intervention of the photocell in opening stops the gate, at its disengagement the gate starts opening again.

**It is necessary to instal the photocell 1**

**properly, in order to cover the action space of the gate.**

Press the *UP* or *DOWN* keys until the display shows:

**Fot 1**

Press the *MENU* key, the display shows one of the 3 writings:

**no** the opening of PHOTO1 is not available  
**APCh** the opening of PHOTO 1 is available for the connection of the photocell  
**Cost** the opening of PHOTO 1 is available for the connection of the rib.

Set the wished functions pressing the *UP* or *DOWN* keys.

Press the *MENU* key to confirm, on the display will appear **Fot1**.

## INPUT PHOTO 2

The photocell 2 is active in closing: if it is dimmed during the closing it stops the gate and inverts the motion. The option CFCh activates the photocell even when the gate is still: closed gate means that no impulse has been given, either it is in pause or it has received a STOP command. In this case through all the time of the darkening of the photocell the control unit does not receive any command of activation at any opening/closing cycle.

Press the *UP* or *DOWN* keys until on the

# PROGRAMMING

display appears:

**Fot2**

Press the *MENU* key, the display shows one of the 3 writings:

**no** the input PHOTO 2 is not available  
**CFCh** the input PHOTO 2 is available: the photocell is active in closing and also when the gate is still  
**Ch** the input PHOTO 2 is available: the photocell is active only during the closing

Set the wished functions pressing the *UP* or *DOWN* keys.

Press the *MENU* key to confirm, on the display will appear **Fot 2**.

## RADIO INPUTS

To each memorized code one of the available four radio inputs is associated, in order to give the control unit the wished command; furthermore with simple and fast operations it is possible to carry out the partial or total clearing of the codes present in memory.

The connection of a modular superheterodyne receiver, allows the use of the four radio channels, **tEL1 tEL2 tEL3 tEL4**, to each a command of the control unit is associated:

**tEL1** → START transmitting the code associated to **tEL1**, the control unit receives a START

**tEL2** → PEDESTRIAN START transmitting the code associated to **tEL2**, the control unit receives a PEDESTRIAN START

**tEL3** → STOP transmitting the code associated to **tEL3**, the control unit receives a STOP

**tEL4** → ACTIVATES THE COURTESY LIGHTS OUTPUT transmitting the code associated to **tEL4**, the control unit activates the **COURTESY LIGHTS** output.

## INSERTING THE WISHED CODES INTO THE MEMORY

To memorize the wished TX codes follow carefully the instructions.

Press the *UP* or *DOWN* keys and select the wished radio input, the display will show: (Example)

**tEL 1**

Press the *MENU* key, the display will show: (Example)

**t-r AS**

The control unit is ready for the radio learning, press the wished remote control key until the display shows:

**r-EC**

Release the remote control key

# PROGRAMMING

The control unit is now ready to learn new codes.

## SUBSTITUTION OF A SINGLE CODE

To substitute a single code already memorized, it's sufficient proceed as explained above.

### END OF PROGRAMMING

This menu allows to finish the programming (both default and personalized) saving the modified data into memory. Press the *UP* or *DOWN* keys until on the display appears:

**FinE**

Press the *MENU* key to confirm, one of the following will appear on the display:

**no** further corrections to carry out: do not quit the programming  
**Si** end of programming

Press the *UP* or *DOWN* keys to select the wished function.

Press the *MENU* key to confirm

If the function is **no**, on the display will appear: **FinE**.

By pressing *UP* or *DOWN* you can scroll the menus to make modifications.

If the function is **Si**, on the display will appear the control panel.

The inserted data have been memorized: the control unit is ready to be used.



## INSTRUCTIONS FOR THE INSTALLATION

The installer must provide for a device (es. magnetothermal switch) ensuring the omnipolar sectioning of the PD4 equipment from the power supply.

The standards require a separation of the contacts of at least 3 mm in each pole (CEI EN 60335-1).

The equipment is designed for non enclosed installations.

For the connection of stiff or flexible tubes and fasteners, use connectors according to IP55 protection grade.

## WARNING LIGHT DESCRIPTION

The warning light shows in real time the state of the gate:

STOP	→ light off
IN PAUSE	→ light always on
DURING OPENING	→ the light flashes slowly (2 Hz)
DURING CLOSING	→ the light flashes rapidly (4 Hz)

## TERMINAL CONNECTIONS

In order to facilitate the connections, the PD4 control unit is equipped with two entirely removable terminal blocks.

# PROGRAMMING

1. Antenna shield.
2. Antenna
3. Opening control for the connection of: push-button panel, key selector, clock. Contact normally open.
4. Opening controls for pedestrian access: contact normally open.
5. Common (-).
6. Stop command. Contact normally closed.
7. Photoelectric cell 1. Contact normally closed.
8. Photoelectric cell 2. Contact normally closed.
9. Common(-).
10. Negative power output 12 Vcc for photoelectric cells and other accessories.
11. Positive power output 12 Vcc for photoelectric cells and other accessories.
- 12.-13. Electric lock or bolt 12 Vcc.
- 14.-15. Warning light 12 Vac 3W.
- 16.-17. Flashing light 12 Vcc 10 W.
- 18.-19. Contact for area lighting 230 Vac 10 A.
- 20.-21. Power output 12 Vcc for motor 2.
- 22.-23. Power output 12 Vcc for motor 1.
24. Negative security battery
25. Positive security battery
- 26.-27. Power supply 12 V a.c.

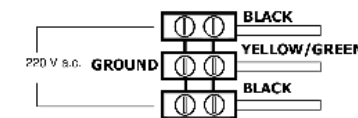

**IMPORTANT:** *the yellow/green cable must be connected.*

## TECHNICAL SPECIFICATIONS

**Power supply:** 230 Vac; 50Hz.  
**Battery capacity:** 12 V 7 Ah  
**Transformer:** PRI 230 V / 50 Hz  
 SEC 12 V / 150 VA  
**Max accessories load powered at 12V:** 5 W  
**Working temperature:** -20°C / +60°C  
**Protection fuses:** 16A for line at 12 Vac

# FUNCTION CHART

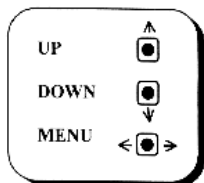

For the use of the function chart proceed as follow:

- press *DOWN* key to flow the chart from the top to the bottom. The functions **dEF**, **t.AP1**, **t.AP2** etc.. will be appear.

- press *UP* key to flow the chart from the bottom to the top;

- press *MENU* key to flow the chart horizontally; for example, if the **t.ChP** function is displayed, by pressing the *MENU* key the number **70** will be displayed. Increase the number pressing *UP* or *DOWN*. Press *MENU* to display function **t.ChP** again.

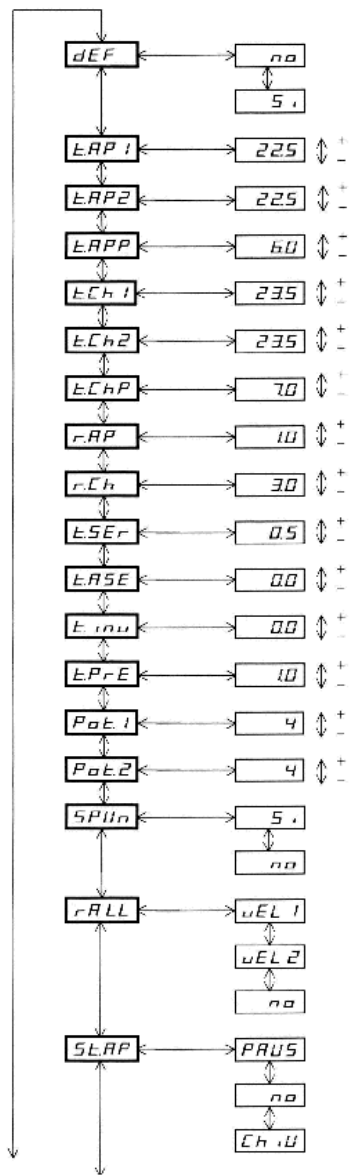

# FUNCTION CHART

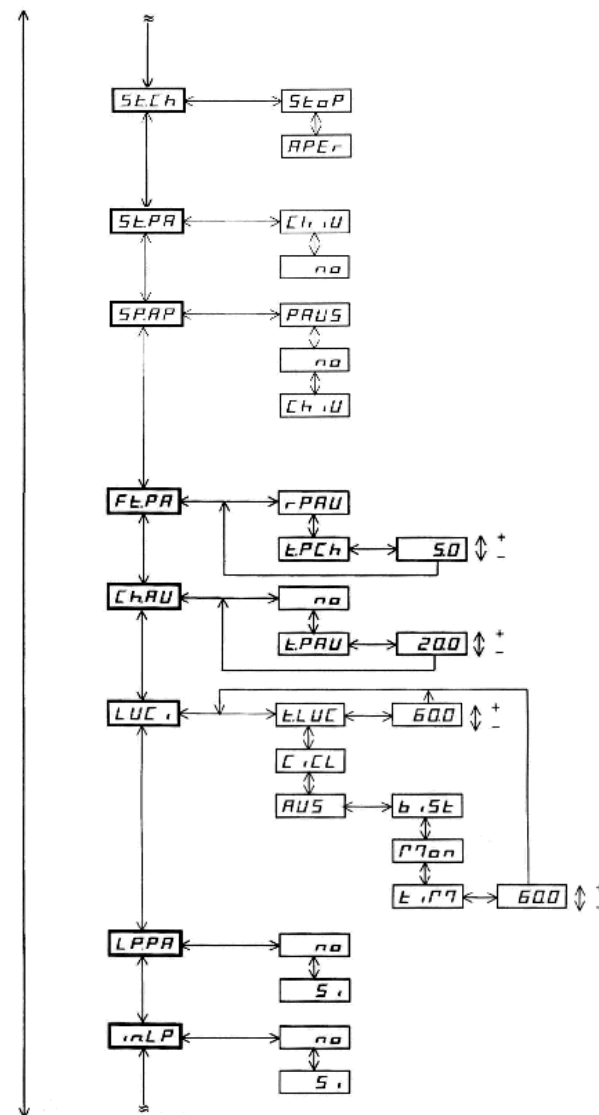

# FUNCTION CHART

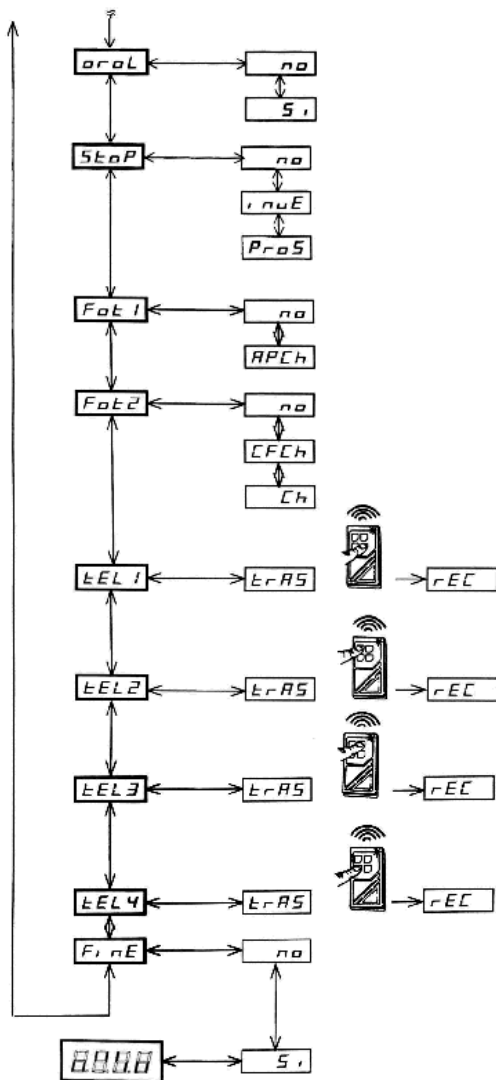

# FUNCTION TABLE PD4

N.	DISPLAY	DATAS	DESCRIPTION	DEFAULT DATAS	MEMO DATAS
0	dEF	no/Si	Load V2 standard datas	no	
1	t.AP1	0 - 120 s	Gate 1 opening time	22.5	
2	t.AP2	0 - 120 s	Gate 2 opening time	22.5	
3	t.APP	0 - t.AP1	Opening time of pedestrian gate	6.0	
4	t.Ch1	0 - 120 s	Gate 1 closing time	23.5	
5	t.Ch2	0 - 120 s	Gate 2 closing time	23.5	
6	t.ChP	0 - t.Ch1	Closing time of pedestrian gate	7.0	
7	r.AP	0 - 120 s	Gate delay during opening	1.0	
8	r.Ch	0 - 120 s	Gate delay during closing	3.0	
9	t.SEr	0 - 120 s	Lock time	3.0	
10	t.ASE	0 - t.SEr	Lock advance time	0.0	
11	t.inv	0 - 120 s	Backlash time	0.0	
12	t.PrE	0 - 120 s	Pre-flashing time	1.0	
13	Pot1	1 to 10	Motor 1 power	4	
14	Pot2	1 to 10	Motor 2 power	4	
15	SPUn	no/Si	Start off	Si	
16	rALL	vEL1 vEL2 no	motor slow down at speed 1 motor slow down at speed 2 motor slow down off	vEL1	
17	St.AP	no ChiU PAUS	Start in opening - START command is not available - command close the gate - stop the gate and goes in Pause	PAUS	
18	St.Ch	Stop APEr	Start in closing - command START stop the gate - command START open the gate	StoP	
19	St.PA	no chiU	Start in pause - START command is not available - START command closes the gate	ChiU	
20	SP.AP	no ChiU PAUS	Pedestrian in opening - P START command is not available - P START closes the gate - gate goes in pause	PAUS	
21	Ft.PA	rPAU t.PCh	Photocell in pause - Pause time recharged - gate stop for a time to be set between 0 to 120 seconds	r.PAU	

# FUNCTION TABLE PD4

N.	DISPLAY	DATAS	DESCRIPTION	DEFAULT DATAS	MEMO DATAS
22	Ch.AU	no t.PAU	Automatic closing - automatic closing not available - reclosing is available, the standstill time is set from 0 to 999 s	No	
23	LUCi	CiCL t.LUC AUS timer bISt Mon	Courtesy light - lights are on trough the whole cycle - lights start time adjustable from 0 to 999 s - auxiliary output --- timed aux out (from 0 to 999 s) --- aux out relay with bistable functioning --- aux out relay with monostable functioning	t.LUC =60 s	
24	LP.PA	no/Si	Flashlight in pause	no	
25	In.LP	no/Si	Flashlight with intermittence	no	
26	OroL	no/Si	Clock function	no	
27	StoP	no invE ProS	Input STOP - input STOP not available - input STOP stops the gate: pressing the command START gate continues the motion - STOP command stops the gate: START command starts moving in the opposite direction	no	
28	Fot 1	no APCh CoSt	Input PHOTO 1 - not available - input is available for the connection of the photocell - input is available for the connection of the rib	no	
29	Fot 2	no CFCh Ch	Input FOTO 2 - not available - input available: photocell is active in closing and also when the gate is still - input available: photocell active during the closing	CFCh	
30	tEL 1		Radio input associated to START command		
31	tEL 2		Radio input associated to Ped START command		
32	tEL 3		Radio input associated to STOP command		
33	tEL 4		Radio input associated to courtesy light		
34	Fine	no/Si	End of programming	no	

# PCB AND CONNECTIONS

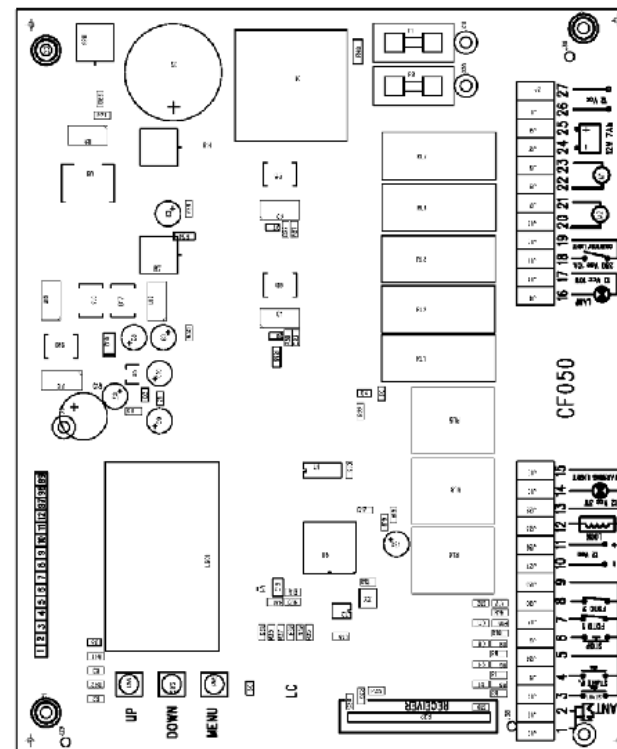

**NOTE** For the connection of the cables to the clamp, use the plastic small band for the cables connected with the accessories and for the cables connected with the supply power