



# Terra

**230VAC ELECTRO-MECHANICAL  
IRREVERSIBLE ACTUATOR FOR  
SWING GATES UP TO 3.5 METRES LENGTH**



**Underground Electro - Mechanical System  
Suitable for gates with up to 3.5M leaves  
Maximum weight 600kg per leaf atT 2.5M**

**High Performance with the  
Aesthetic Advantage of Underground  
Installation**

**Gatestore Ltd**  
682 Anlaby High Road  
Kingston Upon Hull HU3 6UZ  
Tel. 01482 505000  
Fax. 01482 505001  
[www.vidue.co.uk](http://www.vidue.co.uk)

## TERRA



The TERRA underground gate automation system is designed for installations that require a reliable system that has very little visible attachment to the gates. The TERRA, as the name suggests, is designed to install and operate in the ground. The pivot arm that operates the gate becomes its bottom hinge. The TERRA is ideally suited to large heavy gates and where aesthetical appearance is of the essence, as there is mostly no visible sign of the gate being automated. The TERRA is controlled with standard V2 control equipment and can accommodate all the usual ancillaries such as remote control, intercom, digital keypad, auto-close and safety beams to name but a few. We believe that the TERRA is one of the best under floor operators in the world, which explains why it is one of our best selling systems.

The standard system is Grease filled/lubricated

A constant oil bathed unit is available to special order for intensive use where required

## DIMENSIONS

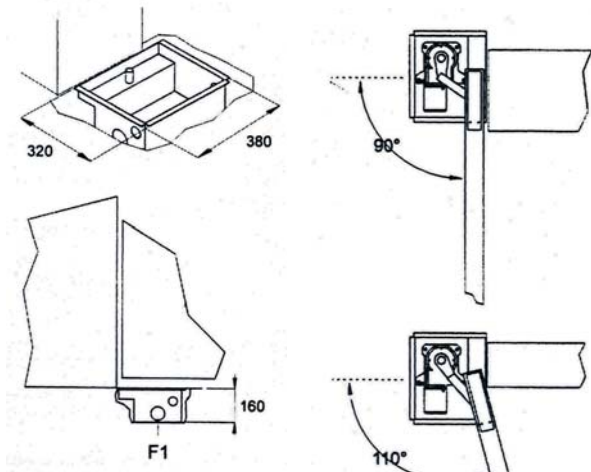

Opening angle can be increased to 180 with optional conversion kit

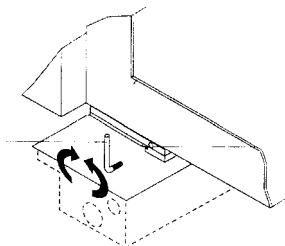

Easy manual release can be operated from either inside or outside the gates in the event of power failure

## KIT TERRA



The TERRA kit pack includes  
 2 steel foundation cases  
 2 TERRA electro-mechanical motors  
 1 control unit  
 2 four channel transmitters  
 1 pair photocells

## COMPATIBLE CONTROL UNITS



Wide range of compatible control units to meet installation requirements:  
**PD5, PD7, PD1, PRGU433PP**

## SPECIFICATIONS

Max Leaf Length	3.5mt
Max Leaf Weight	600Kg
Motor Power	300 W
Max. Thrust	450Kg
Operating Speed	.125 mt/sec
Working Temp	-25° +70° C
Thermal Protection	110°
Motor Weight	12.5Kg

## CONTROL OPTIONS



Key Switch



Wire Free Key Pad