



Installation Manual

TERRA electromechanical gate operators



INTRODUCTION

The **TERRA** motor is an electromechanical operator which is suitable for the automation of metal and wooden swing gates. Two systems are available,

- TERRA/2** - Suitable for double gates with a maximum leaf size of 3.5m (total span of 7.0m)
- TERRA/1** - Suitable for single gate with a maximum width of 3.5 m

Please identify which system you have purchased and read the instructions before continuing with the installation.

INSTALLATION REQUIREMENTS

PLEASE READ THE FOLLOWING INFORMATION CAREFULLY AND ENSURE THAT ALL REQUIREMENTS ARE OBTAINABLE BEFORE INSTALLATION.

- Gates must not exceed the maximum length as stated in Introduction.
- TERRA motors have certain space requirements for fitting. These must be followed as closely as possible.
- Physical stops are required, these are incorporated within the motors. External stops can be fitted if preferred.
- Drive arms that are supplied may not be suited to the gate you are automating as all applications vary. Drive arms may need fabricating/altering.
- A 240vac power supply is required to one side of the gate (where the control unit is to be housed) fused at 13amps - complete with an RCD protection device.
- If a hardwired intercom system or other controls from the house are to be installed, a communications cable will be needed from the house to control unit. Suitably protected "Cat 5" cable is ideal.
- A duct between the posts is required to carry cables to second motor and to connect safety beams.
- The services of a qualified electrician may be required to carry out electrical connections and power supplies/communication cable routing.

TECHNICAL DETAILS

	TERRA
Power Supply	230vac - 50/60Hz
Power	350 W
Capacitor	12.5 MF
Thermal protection cut-in	150°
Direction of rotation	2
Self-locking	yes
Electric motor speed	1400 R.P.M
Torque	Nm. 500
360° rotation time	78 sec
90° opening time	19 sec
Maximum gate length	3500mm
Maximum gate weight	600kg

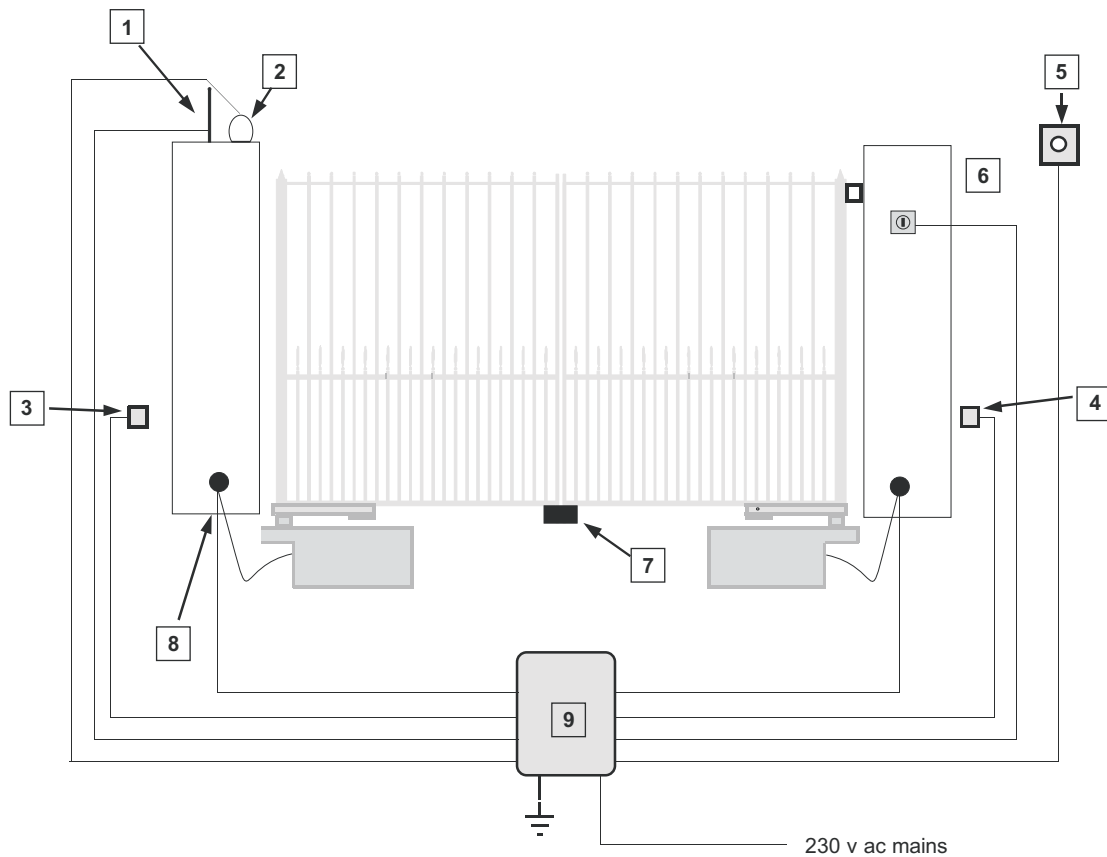

1 - Optional Antenna. Gives added range to your remote transmitter. Recommended fitting location is a high point with a clear line of sight. Usually at the top of you post.

2 - Optional Warning light - 3 x 1.5mm wire. Emits a flashing light to warn others that an automatic gate is in operation. Recommended fitting location is a high point with a clear line of sight. Usually at the top of post.

3- Safety photocell (receiver) - 4 x 0.5mm wire & 4- Safety photocell transmitter - 2 x 0.5mm wire. Photocells are used as a safety feature. We recommend that the photocells are installed for the safety of vehicles and pedestrians. Photocells pass an infra-red beam between themselves. If the beam is broken when the gate is closing or about to start closing the gates will stop.. Recommended fitting location is between your gate pillars on the outside (opposite to the movement of the gate, therefore the gate will not break their beam during the cycle) at a height of approximately 600mm from floor level.

5- Internal push button station/access facility (optional) - 2 x 0.5mm wire. A standard push button switch can be fitted to Release the gate from inside the property or at the gate.

6- Key switch - 2 x 0.5mm wire. Used to access the gates with a conventional key. Recommended fitting location is on the gate pillar, inside or out, depending on the required function.

7- Gate stop . Optional as the TERRA has inbuilt mechanical stops in both the open and closed position

8- Junction boxes for motors - 4 x 1.5mm wire. Used to connect the motor cable to cable from PRGU/CITY1 control unit.

9- Main control unit. Central control unit where all connections are made. Please refer to separate instruction manual for wiring diagrams and operational functions. Recommended fitting location is local to gates behind gate post or fixed to the back of adjacent wall.

Please note, all fitting locations are recommendations only.

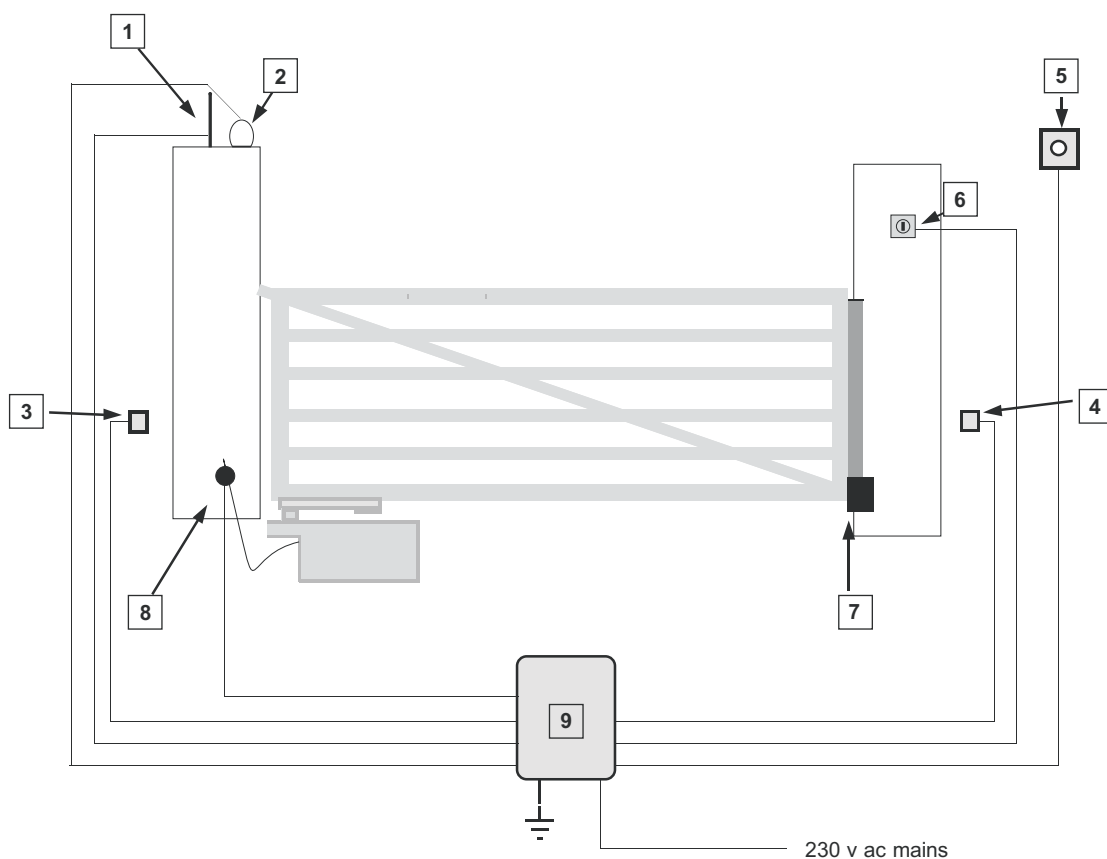

1 - Optional antenna Gives added range to your remote transmitter. Recommended fitting location is a high point with a clear line of sight. Usually at the top of your post.

2 - Optional Warning light - 3 x 1.5mm wire. Emits a flashing light to warn others that an automatic gate is in operation. Recommended fitting location is a high point with a clear line of sight. Usually at the top of post.

3- Safety photocell (receiver) - 4 x 0.5mm wire **& 4- Safety photocell transmitter** - 2 x 0.5mm wire. Photocells are used as a safety feature. We recommend that the photocells are installed for the safety of vehicles and pedestrians. Photocells pass an infra-red beam between themselves. If the beam is broken when the gate is closing or about to start closing the gates will stop.. Recommended fitting location is between your gate pillars on the outside (opposite to the movement of the gate, therefore the gate will not break their beam during the cycle) at a height of approximately 600mm from floor level.

5- Internal push button station/access facility (optional) - 2 x 0.5mm wire. Creates a normally open volt free switch to release the gate from inside the property or at the gate.

6- Key switch - 2 x 0.5mm wire. Used to access the gate with a conventional key. Recommended fitting location is on the gate pillar, inside or out, depending on the required function.

7- Gate stop. Optional as the TERRA has inbuilt mechanical stops in both the open and closed position

8- Junction box for motor - 4 x 1.5mm wire. Used to connect the motor cable to the cable from PRGU/CITY1 control unit.

9- Main Control Panel. Central control unit where all connections are made. Please refer to separate instruction manual for wiring diagrams and operational functions. Recommended fitting location is local to gate behind gate post or fixed to the back of adjacent wall.

Please note, for single gates exceeding 3.0m we recommend the use of an electric lock. This secures the gate when closed and eliminates any unnecessary damage to the drive.

TERRA - MOTOR INSTALLATION (recommendation only)

- Check that you have all listed components.
- Check **Installation requirements** on page 1 and ensure that the application satisfies all points.
- Using *Fig. 3/4 & 5*, Calculate the correct position for your motor box, respecting the position of your gate hinges.
- Dig holes to accommodate your motor boxes ensuring that there is sufficient space underneath the box (for drainage purposes) and around each side of the box (for securing well with concrete). Ensure that when in position, the pivot shaft of motor box is in line with the top hinge of your gate.
- Once the hole is prepared, lay a bed of sand at the base of the hole (this is optional but is ideal drainage for motors).
- Position your motor box in the hole ensuring that the top of the box is flush with your finished floor level and that all positional requirements have been followed. *Fig. 5* Shows that 55mm is the correct distance requirement from cover plate/finish floor level to underside of your gate. This distance must be respected for when the motor arm is attached. If the distance is greater than 55mm, the difference will need to be compensated for with a form of bracket (*Fig. 6*)
- Insert a duct (preferably a flexible conduit) through one of the cable holes of the box leading to your nearest gate post. Feed your motor cable through this duct and terminate at the gate post with junction box. This cable will be wired back to your control unit when electrical connections are made. It is also beneficial to insert further ducts from the box into the ground for drainage purposes.
- Concrete around the box. Ensure that a strong concrete mix is used and that the motor is firmly secure when set.
- Once set, insert the motor into the box in the correct position (*Fig. 7*) and secure tightly.
- Insert pivot bearing into drive arm shaft and lubricate. Lubricate drive shaft and attach drive arm.
- Offer the arm to the underside of the bottom rail of your gate to calculate fixing position. If alteration of the bracket is required, modify drive arm and continue.
- Fix the drive arm to the gate, preferably welding if gate is metal.
- Link motor to drive arm with connector arm. You may find that once connected the gate is at an open angle. This is correct and is restored during system test
- Set the inbuilt limit stops if required
- Replace foundation box cover and secure firmly with supplied screws.

Motor cable, **Blue** = common, **Brown & Black** = direction (open & close), **Green** = earth.

If your system has two motors **TERRA/2**, please repeat the same installation procedure for the second motor/gate.

TERRA INSTALLATION - Electrical connection

YOU MAY WISH TO HAVE A QUALIFIED ELECTRICIAN CARRY OUT THE ELECTRICAL CONNECTION

For full wiring instruction of motor and accessories, please refer to the control unit manual.

TERRA INSTALLATION - System test

Upon completion of mechanical installation and electrical connection we recommend that the system is tested. Please follow the test procedure below,

- Apply power.
- Decrease power setting in the control unit to avoid damage to motor casing.
- Give signal from access unit i.e. transmitter, key switch.

At the initial signal the motors should always move in the opening direction, if this is not the case for one or both of the motors the directional wires (brown & black) of each incorrect motor must be reversed.

- Run motors for a number of operations to evaluate whether any operational timer adjustments are needed. These timers are found in control unit and include, **run timer** (amount of time motors are running for), **delay timer** (allowing a delay between first and second motor-PRGU only), **pause timer** (amount of time motors remain open before closing), **power control** (regulates power supplied to motors). All timer adjustments are detailed in control unit instruction.

Please note, system is not initially set up for automatic closure. If this is required, please refer to control unit instruction to alter the system operation.

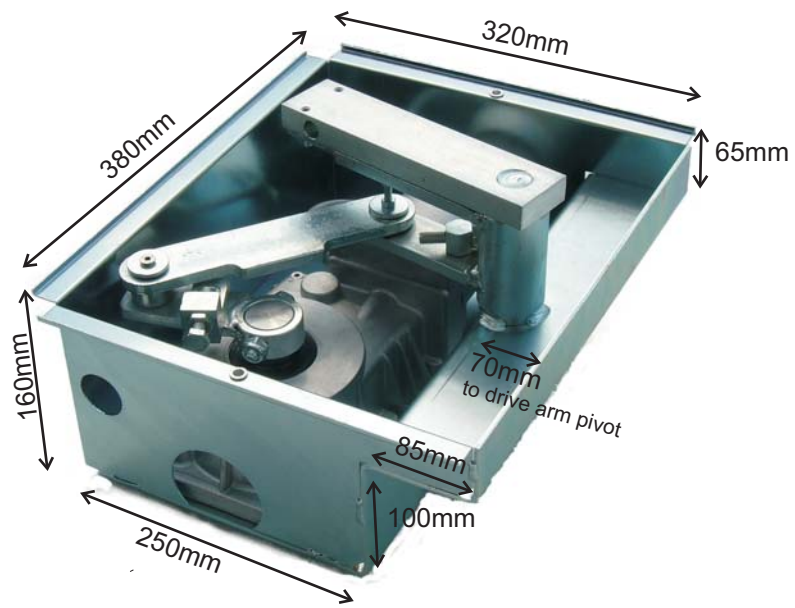

Foundation Case Dimensions

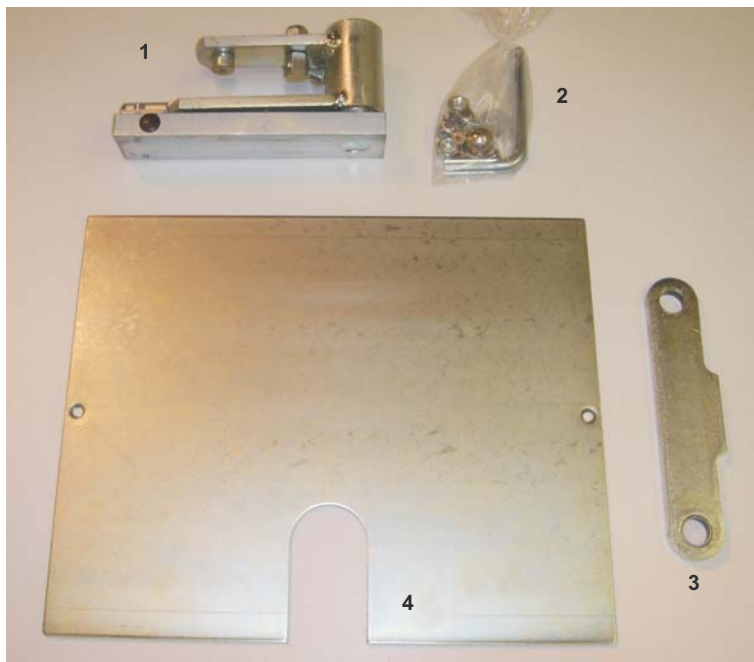

- 1 DRIVE ARM COMPLETE WITH MECHANICAL STOP
- 2 MANUAL RELEASE KEY, BEARING AND BOLTS
- 3 CONNECTOR ARM
- 4 COVER PLATE

Fig 3 - Installation of motors when gate is hinged on inside face of post - up to 90° opening

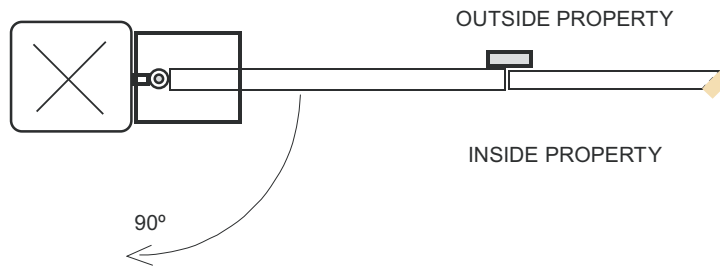

Fig 4 - Installation of motors when gate is hinged on back face of post - up to 90° opening

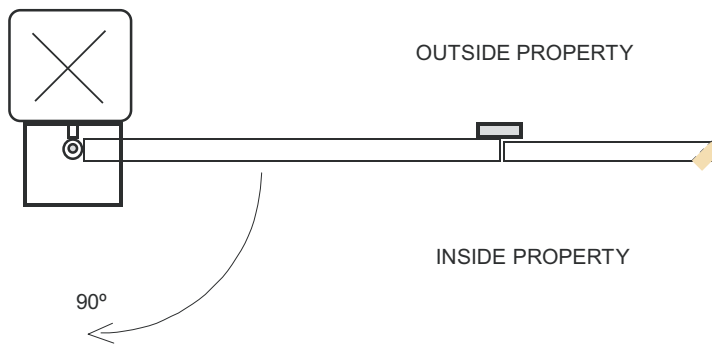

Fig 5 - Foundation box dimensions

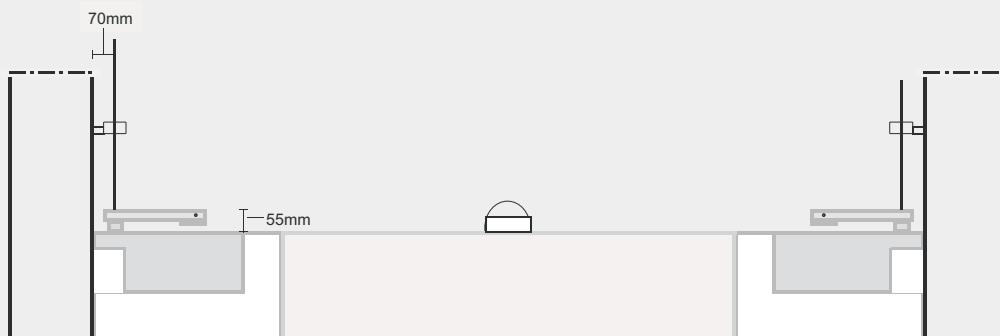

Fig 6 - Drive arm modification

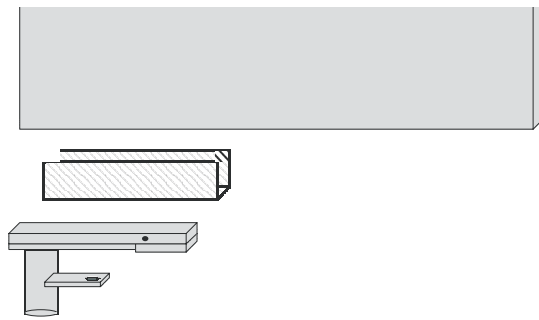
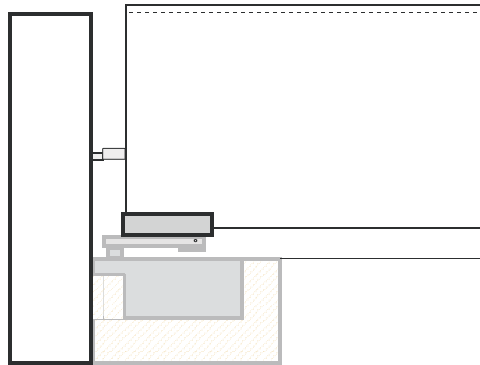
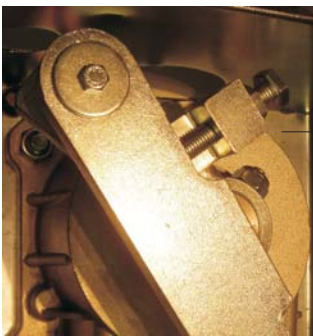

Fig. 7- Assembly of connector arm



Mechanical Stop Detail



Right hand motor as viewed from inside property In closed position.



Right hand motor as viewed from inside property In 90° open position.

EMERGENCY OPERATION - Manual release

In the event of a power failure situation, you may open your gates using the manual release function. Manual release is achieved by inserting the manual release key into the drive arm release key hole and rotating . The arm then separates from the holding section and you may open the gates manually.

Once power is restored, reverse the manual release procedure and give the gate system a signal from your transmitter. The arms will re-connect during operation and function as normal.

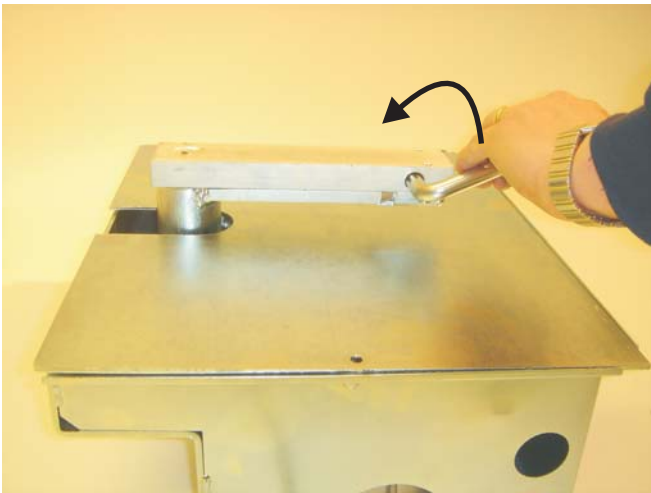

SERVICE

If you require service please contact: